

# *LONG UNIVERSAL ENGINE SUPPORT*



*ISTRUZIONI PER L'USO*



*INSTRUCTION FOR USE*



*MODE D'EMPLOI*



*GEBRAUCHSANWEISUNG*



*INSTRUCCIONES*



*INSTRUCOES DE USO*



*GEBRUIKSAANWIJZING*



*INSTRUKCJA OBSLUGI*



European Patent

Nr. 2072452B1

# 1. *INSTRUCTION FOR USE*

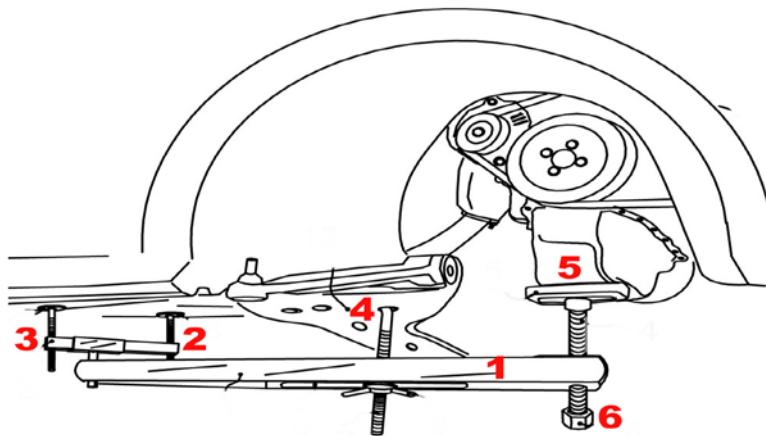

Fissare la **TRAVERSA 1** inserendo il **GANCIO 4** in un foro o in un appiglio il più possibile vicino al motore. In mancanza di fori o appigli impiegare anche la **FASCIA 8**. Ruotare manualmente il **MECCANISMO 6** per alzare il **TAMPONE 5** fino al motore. Stabilizzare la **TRAVERSA 1** mediante il **TUBO 2** e i **PERNI 3**; Utilizzare il **KIT 9** per i veicoli commerciali.



Fix **CENTRAL CROSSBEAM 1** by inserting **HOOK 4** in a hole or anchorage point as near as possible to the engine. **BAND 8** is to be used only when holes or anchorage points are missing. Rotate **MECHANISM 6** manually in order to raise **BUFFER 5** till the engine. Fasten **CENTRAL CROSSBEAM 1** through **TUBE 2** and through **ROTS 3**; **KIT 9** is to be used only for commercial vehicles.



Fixer le **MOTEUR SUPPORT 1** en insérant le **CROCHET 4** dans un trou ou dans un point d'appui le plus proche possible du moteur. En l'absence des trous ou de points d'appui utiliser aussi la **BANDE 8**. Faire tourner manuellement le **MÉCANISME 6** pour soulever le **TAMPON 5** jusqu'au moteur. Stabiliser le **MOTEUR SUPPORT 1** avec le **TUYAU 2** et les **TIGES 3**; utiliser le **KIT 9** seulement pour les véhicules commerciaux.



Befestigen Sie den **HAKEN 4** in einem Loch oder Verankerungspunkt so nah wie möglich am Motor, um die **MOTOR GETRIEBESTÜTZE 1** festzumachen. Verwenden Sie das **BAND 8** nur wenn es keine Löcher oder Verankerungspunkte gibt. Drehen Sie manuell den **MECHANISMUS 6**, um den **PUFFER 6** bis zum Motor anzuheben. Befestigen Sie die **MOTOR GETRIEBESTÜTZE 1** mit dem **ROHR 2** und mit den **VERSTELLBAREN FÜSSEN 3**; Verwenden Sie **KIT 9** nur für Nutzfahrzeuge.



Fijar el **SOPORTE MOTORE 1** insertando el **GANCHO 4** en un agujero o en un punto de apoyo lo más cerca posible del motor. En ausencia de agujeros o mangos utilizar también la **BANDA 8**. Girar manualmente el **MECANISMO 6** para levantar el **TAMPÓN 5** hasta el motor. Estabilizar el **SOPORTE MOTORE 1** mediante el **TUBO 2** y los **VARILLAS 3**; utilizar el **KIT 9** sólo para los vehículos comerciales.



Corrigir o **CRUZ 1**, inserindo o **GANCHO 4** num furo ou numa posição tão próximo quanto possível do motor. Na ausência de furos ou pegas também utilizar a **BANDA 8**. Rodar manualmente o **MECANISMO 6** para levantar o **PAD 5** para o motor. Estabilizar **CRUZ 1** por pinos **TUBO 2** e **3**; **KIT 9** para veículos comerciais.



Bevestig de **CROSS 1** van de **HAAK 4** in een gat of in een positie zo dicht mogelijk bij de motor. In de afwezigheid van gaten of handgrepen ook gebruik maken van de **BAND 8**. Handmatig roteren Het **MECHANISME 6** van de **PAD 5** verhogen tot de motor. Stabiliseren **CROSS 1** door **TUBE PINS 2** en **3**; het gebruik van **KIT 9** voor bedrijfswagens.



**MOCOWANIA SILNIKA 1** . włożyć **HAK 4** do otworu, lub uchwycem jak najbliżej silnika. W przypadku braku dziur lub uchwytów korzystać także z **PASMA 8**. obrócić Ręcznie **MECHANIZM 6** zeby podnieść bufor aż do silnika . Ustabilizować **MOCOWANIA SILNIKA 1** poprzez **RURE 2** i **SWORZNI 3**; **SWORZNI 9** dla pojazdów użytkowych.

## 2. ATTENTION

### INSTRUCTIONS:

Max 250 kg

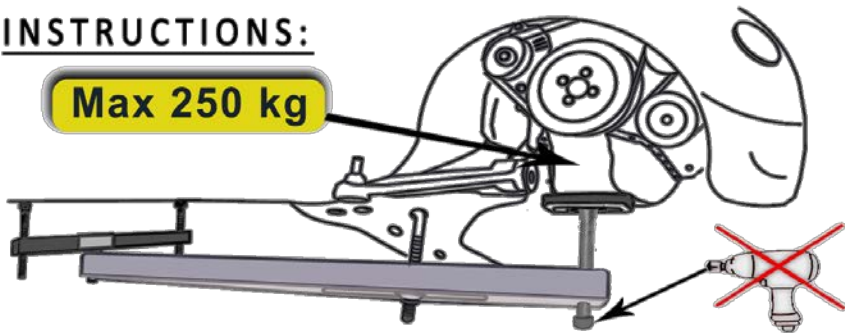

### ACCESSORIES:

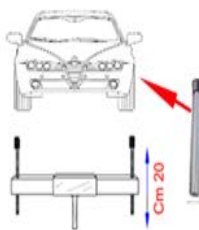

### KIT N°9

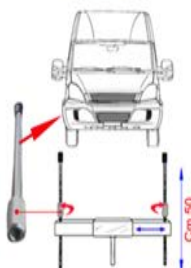

### BAND N°8

### ACCESSORIES:

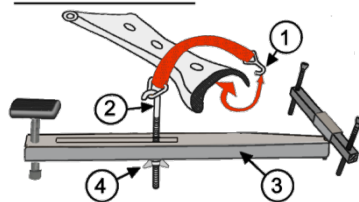

**ATTENZIONE !** Usare la fascia N°8 solo in mancanza di fori o punti per fissare il gancio N°2.



**WARNING ! Use band N°8 only in the absence of holes or points to secure the hook N°2.**



**ATTENTION! Utiliser la bande N°8 seulement en l'absence de trous ou de points pour fixer le crochet N°2.**



**ACHTUNG! Verwendung des Endes N°8 nur in Abwesenheit von Löchern oder Punkten zur Sicherung des hakens N°2.**



**¡ATENCIÓN! Utilizar el extremo N°8 sólo en la ausencia de agujeros o puntos para asegurar el gancho N°2.**



**ATENÇÃO! Utilizar o fim N°8 apenas na ausência de furos ou pontos para fixar o gancho N°2.**



**VOORZICHTIG! Gebruik alleen in de afwezigheid van gaten of punten van de band N°8 bij het verankeren de haak N°2.**



**UWAGA! Użycie końca N°8 tylko w przypadku braku otworów lub punktów zamocowania haka N°2**

# INSTRUCTIONS FOR USE

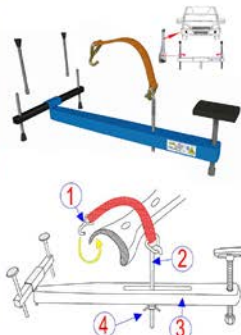
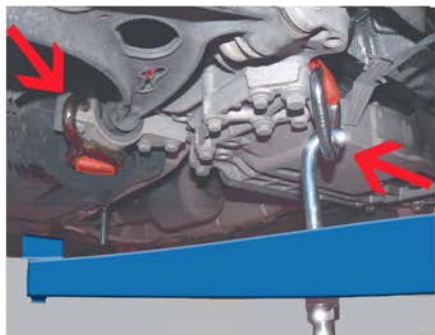

# 3. TECHNICAL DATA

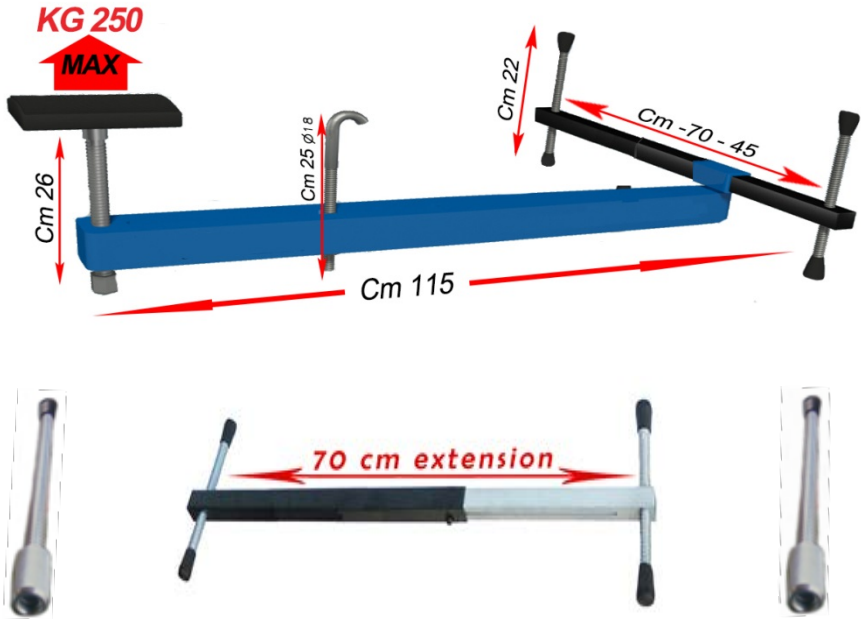

Height	20 cm
Width	50 cm
Weight	12 kg
Length	115 cm
Maximum Capacity	250 kg
Extension	50 – 70 cm
Max Jack Height	26 cm



